

ARI

TITANIUM
PLUS
TITANIUM PLUS**COMFORT**

- High V40

EFFICIENCY&ENERGY SAVING

- Ecological polyurethane insulation

QUALITY

- Titanium glasslined inner tank tested at 12 bar
- Oversize magnesium anode
- 6-bolts flange
- Pressure safety valve rated at 6 bar

DESIGN

- Exclusive Italian design
- Wall-hung

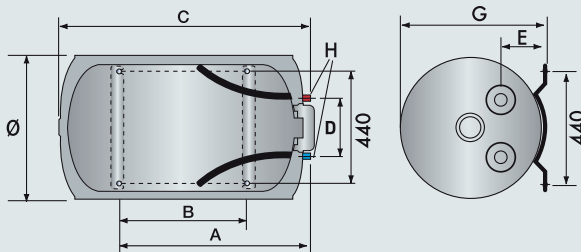
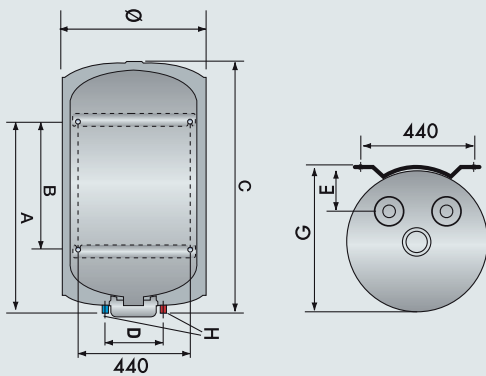

easy
and safe

**TECHNICAL DATA**

		ARI 150 V THER	ARI 150 H THER	ARI 200 V THER	ARI 200 H THER
Nominal Capacity	L	150	150	200	200
Power	kW	1.8	2	2.2	2
Voltage	V	230	230	230	230
Heating time (deltaT= 50°C)	h.min	5.10	4.40	5.35	5.50
Heat dispersion	kWh/24h	1.41	1.68	1.85	2.06
Max working temp.	°C	65	75	65	75
Protection	IP	IP25D	IP25	IP25D	IP25
Weight	kg	37	39	45	47

OVERALL DIMENSIONS

		ARI 150 V THER	ARI 150 H THER	ARI 200 V THER	ARI 200 H THER
a	mm	750	750	1050	1050
b	mm	500	500	800	800
c	mm	1010	1020	1270	1285
d	mm	230	230	230	230
e	mm	175	180	175	180
f	mm	560	570	560	570
g	mm	575	585	575	585
h	mm	G3/4	G3/4	G3/4	G3/4

CODE (UAE)

3010909 3010907 3010910 3010908

CODE

3000326 3010895 3000327 3010899

LEGEND

- E** Cold water inlet G 3/4"
- U** Hot water outlet G 3/4"

NOTE: The Nominal capacity listed in this catalogue identifies the product category.
The actual product capacity is listed in the relative technical documentation.